

GENERAL APPLICABILITY

HYUNDA ELANTRA 2017

KIT CONTENTS/SERVICE PARTS

ITEM	QTY	DESCRIPTION	PART#
1	1	CRUISE CONTROL MODULE	250-2763
2	1	MAIN HARNESS	250-2759
3	1	SWITCH HARNESS	250-2760
4	1	PEDAL INTERFACE HARNESS	250-2928
5	1	CONTROL SWITCH	250-2867

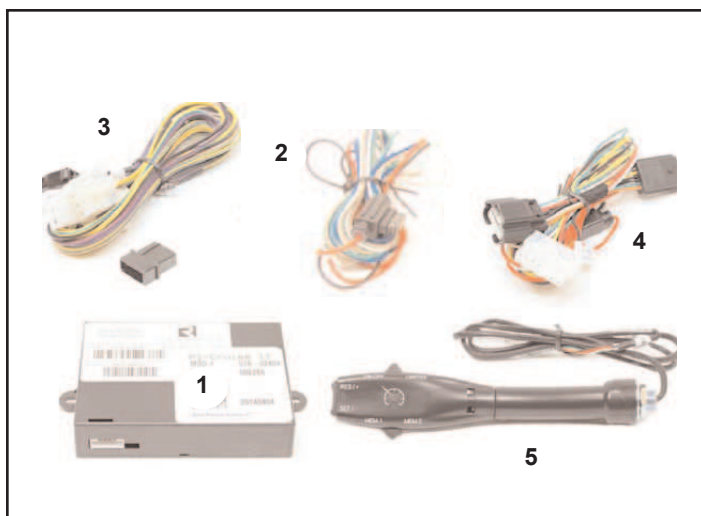

HARDWARE BAG CONTENTS

ITEM	QTY	DESCRIPTION
1	8	WIRE ZIP TIES
2		
3		







RECOMMENDED TOOLS

PERSONAL & VEHICLE PROTECTION	
SAFETY GLASSES	
SPECIAL TOOLS	
VOLT-OHM METER	
INSTALLATION TOOLS	
TRIM REMOVAL TOOL	PHILLIPS SCREWDRIVER
10-MM WRENCH	
DRILL BITS	9/32 (FOR SWITCH)
14MM WRENCH	
SOLDERING TOOL	
SPECIAL CHEMICALS	

CONFLICTS

NOTE:

LEGEND

-  **STOP:** DAMAGE TO VEHICLE MAY OCCUR. DO NOT PROCEED UNTIL PROCESS COMPLIANCE HAS BEEN MET.
-  **OPERATOR SAFETY:** USE CAUTION TO AVOID RISK OF INJURY.
-  **CRITICAL PROCESS:** PROCEED WITH CAUTION TO ENSURE A QUALITY INSTALLATION. THESE POINTS WILL BE AUDITED ON A COMPLETED VEHICLE INSTALLATION.
-  **GENERAL PROCESS:** THIS HIGHLIGHTS SPECIFIC PROCESSES TO ENSURE A QUALITY INSTALLATION. THESE POINTS WILL BE AUDITED DURING THE ACCESSORY INSTALLATION.
-  **TOOLS & EQUIPMENT:** THIS CALLS OUT THE SPECIFIC TOOLS AND EQUIPMENT REQUIRED FOR THE PROCESS.
-  **REVISION MARK:** THIS MARK HIGHLIGHTS A CHANGE IN INSTALLATION WITH RESPECT TO PREVIOUS ISSUE.



WARNING: DO NOT USE HAND-HELD 2-WAY TRANSCEIVERS INSIDE YOUR VEHICLE WHILE DRIVING.

WHEN TRANSMITTING FROM INSIDE THE CAR, 2-WAY RADIOS THAT OPERATE IN THE 25MHZ-700MHZ FREQUENCY RANGE WITH MORE THAN 2.0 WATTS OF POWER CAN PRODUCE ELECTROMAGNETIC INTERFERENCE THAT COULD INTERFERE WITH THE OPERATION OF CRUISE AND THROTTLE CONTROLS RESULTING IN VEHICLE "LIMP MODE".

USE OF CELLULAR PHONES WILL NOT INTERFERE WITH THESE CONTROLS.



DUE TO SENSITIVE NATURE OF SIGNALS USED FOR THIS PRODUCT, ALL NON-PLUG AND PLAY CONNECTIONS MUST BE SOLDERED. FAILURE TO COMPLY WITH THIS REQUIREMENT WILL VOID WARRANTY.



BEFORE INSTALLATION

TO MAKE THE INSTALLATION EASIER, THE COMPLETE INSTALLATION INSTRUCTIONS SHOULD BE READ THROUGH BEFORE INSTALLATION IS STARTED.

THIS INSTALLATION INSTRUCTION CONTAINS INFORMATION HOW TO INSTALL THE ELECTRONIC CRUISE CONTROL WHICH IS NOT A Do-It-Yourself JOB.

MODERN CARS ARE EQUIPPED WITH ELECTRONICS WHICH CAN BE COSTLY WHEN DAMAGED BY INAPPROPRIATE TREATMENT.

ROSTRA PRECISION CONTROLS CAN NOT BE HELD RESPONSIBLE FOR ANY ERROR CAUSED BY WRONG INSTALLATION.



STOP - READ BEFORE INSTALLATION IMPORTANT ADVISORY NOTES THAT YOU MUST FOLLOW

ALWAYS DISCONNECT THE NEGATIVE CABLE FROM BATTERY BEFORE INSTALLATION.

ALWAYS USE THE ENCLOSED INSTALLATION INSTRUCTION FOR INSTALLING THE ELECTRONIC CRUISE CONTROL.

CHECK THE PART NUMBER OF THE CRUISE MODULE LABEL IS THE SAME COMPARED TO THE PART NUMBER OF THE INSTALLATION INSTRUCTIONS.

BE AWARE OF RADIO CODES THAT MIGHT HAVE TO BE TYPED IN.

FIND A LOCATION TO INSTALL THE CRUISE MODULE AND CONTROL SWITCH.

IF ANY WIRES ARE LEFT, THEN CUT OFF AND INSULATE.

ONLY USE A MULTIMETER TO MEASURE VOLTAGE.

ALWAYS DRIVE THE CAR FOR A COMPLETE TEST BEFORE REASSEMBLING THE CAR.

ALL WIRE LEADS MUST BE SOLDERED.

PART NUMBER: 250-1884

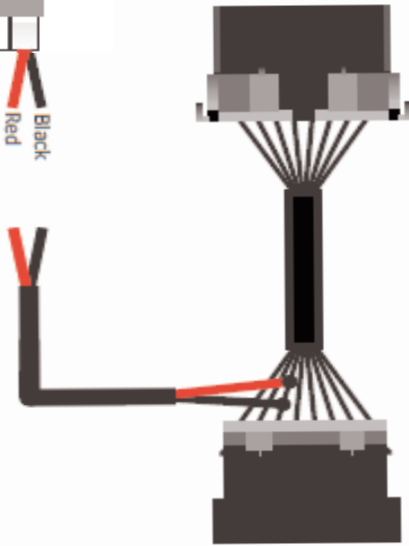
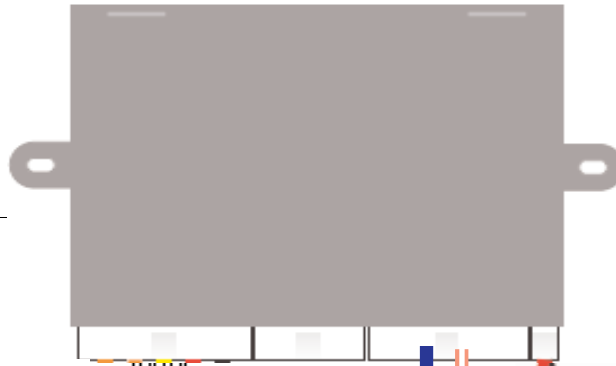
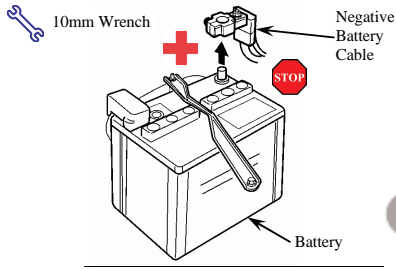

To OBD2 Connector

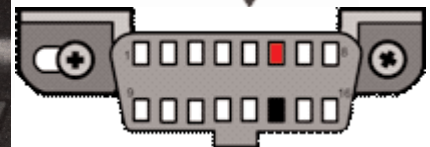

Brake switch Connector at top of Brake Pedal Assembly

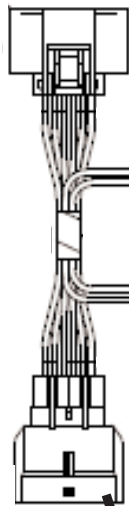

Connect to the accelerator pedal

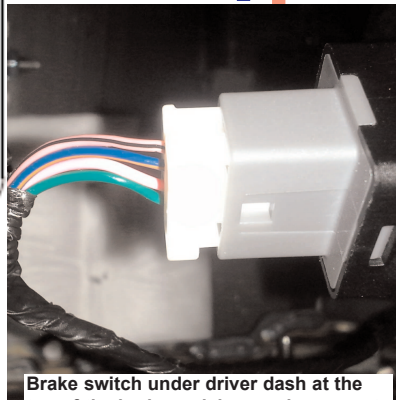
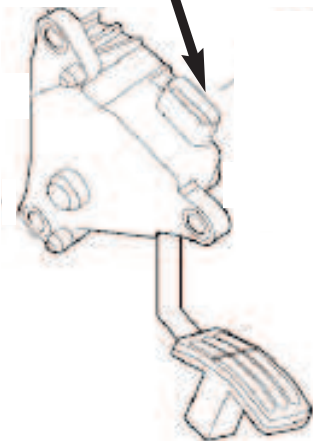

Brake switch under driver dash at the top of the brake pedal assembly connect cruise harness Blue and Brown/White wires to brake switch: cruise harness Blue to PINK of brake switch. Cruise harness Brown/White to GREEN of brake switch.

PART NUMBER: 250-1884



Clutch Cancel

If Manual Transmission: connect the YELLOW wire of cruise harness to Positive trigger wire of existing top clutch switch in vehicle. This wire will go to voltage only when clutch is pressed. There is no distinctive vehicle wire color listed and will need to be checked with Volt/OHM Meter.

Ground

Connect BLACK ground wire to factory ground located under drivers dash or Drivers kick panel

Ignition Red Wire

Connect RED wire at Ignition 12 volts PINK wire IGNITION SWITCH WHITE 6 PIN CONN. PIN 4

NOTE: This cruise uses a universal harness for input circuits, any wires not listed in this instruction for vehicle connection will not be used.



Connect the Violet wire VSS SIGNAL to 24 pin connector in Radio harness to Head Unit position 14 white wire.

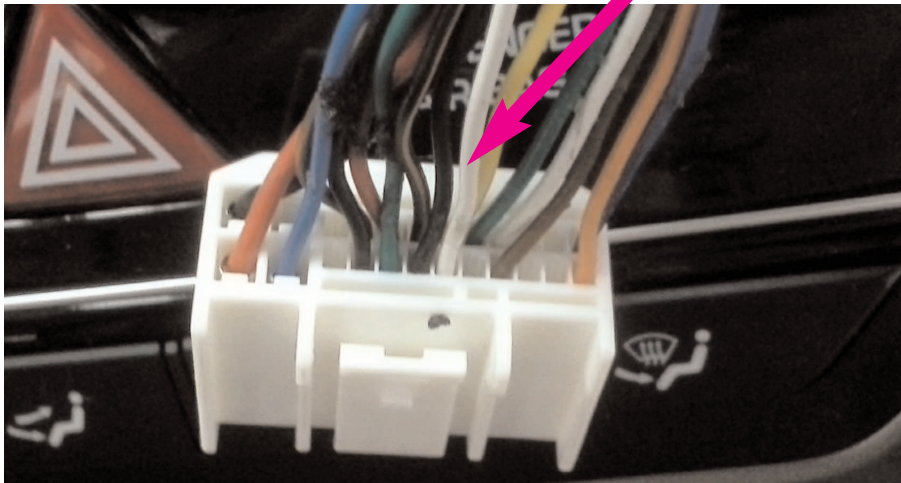

For Radio removal concerns or questions please review our YouTube video by visiting our website www.rostra.com and clicking on the YouTube link.

PART NUMBER: 250-1884

1. Find a suitable position for the switch on the left hand side of the covering around the steering column.
 2. Mark the position and drill 3/8" or 9.5mm hole.
 3. Use the enclosed fittings so the switch is angled to match the OE turn signal switch lever.
 4. The switch head can be rotated as desired, and locked with the supplied retainer clip.
 5. Insert the wires in the dconnectors to plug into cruise module shown below.
- NOTE: All pin insertions shown are from wire side of connector.

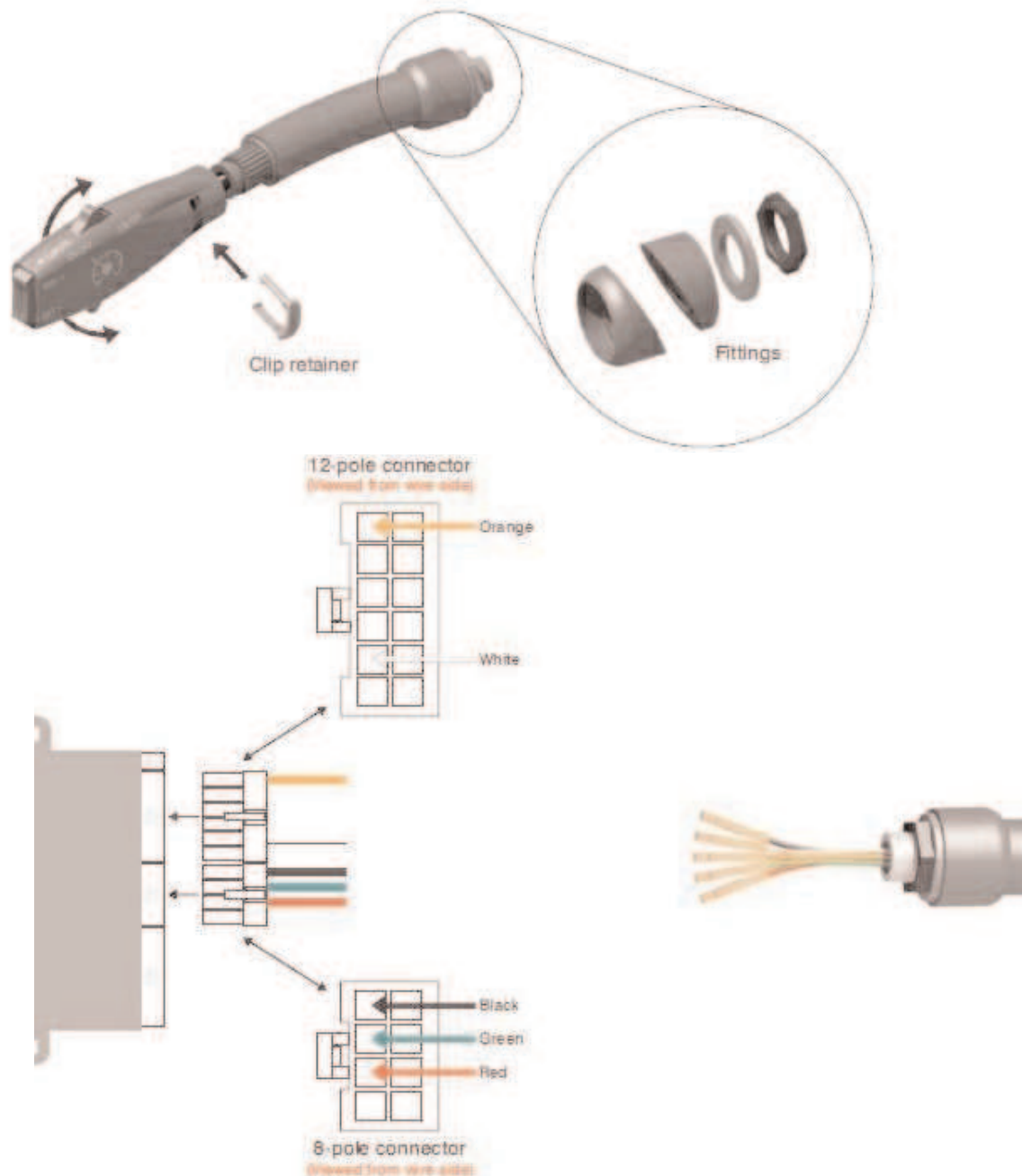

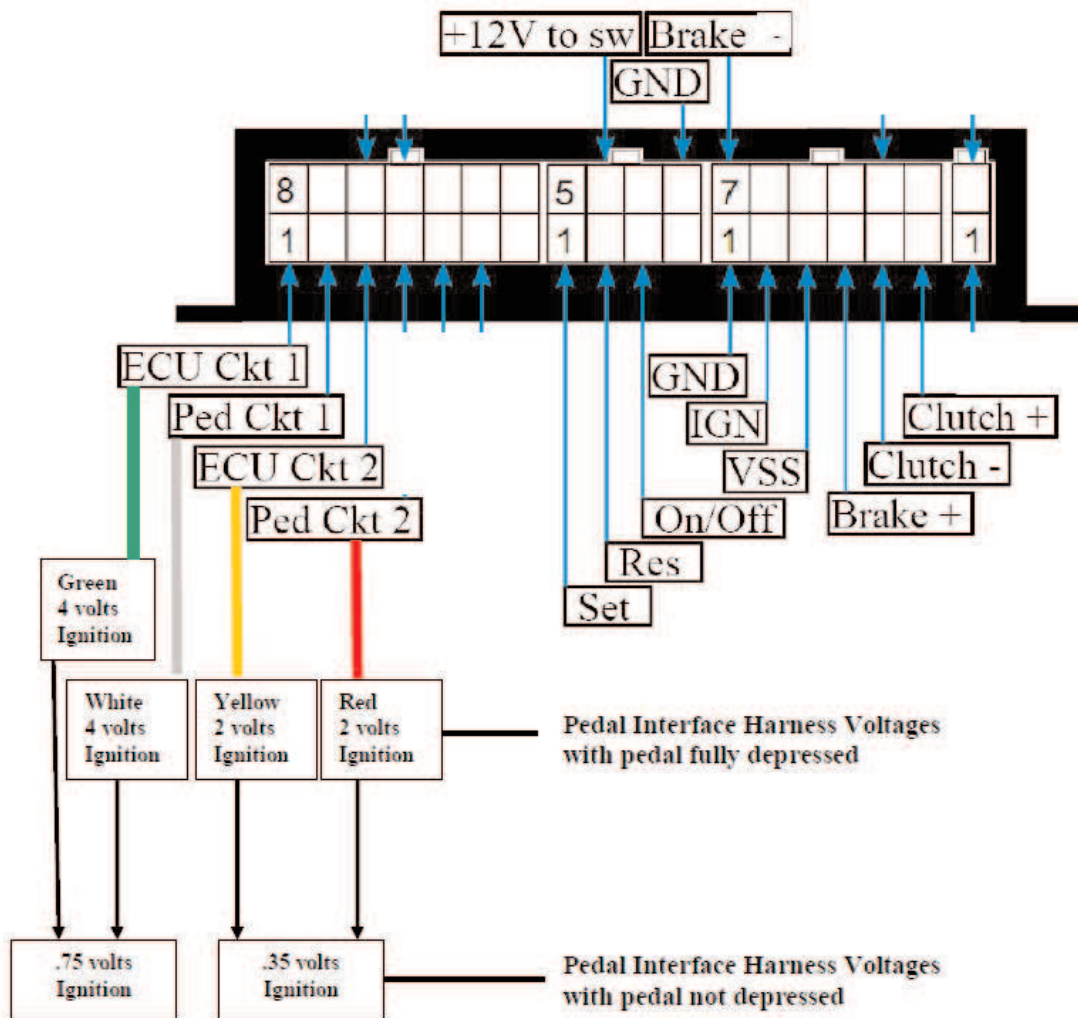

TROUBLESHOOTING

Function	Color	Results	Fault Conditions
Ignition	Red	+12V when switched on and +0V when switched off. Ignition must be greater than +10V while cranking vehicle.	No power, voltage drop or intermittent connection will cause loss of pedal or "Limp Mode" condition.
Brake positive +	Blue	"Hot" side of brake switch. +12V all the time.	Cruise will not function if this connection is not installed correctly.
Brake negative -	Brown/White	"Cold" side of Brake switch. Zero (0) resistance to ground when brake is not pressed. +12V when brake is pressed.	Cruise will not function if this connection is not installed correctly. If connection is good, and there is a high resistance to ground, a 5 terminal relay will be required to complete installation. See diagram below.
Ground	Black	Lowest resistance to ground closest to zero (0) ohms as possible. Use a vehicle ground point where other ground wires are connected to.	A bad ground connection will cause the following conditions: cruise will not function: loss of pedal or "Limp Mode" condition.
Clutch (GND triggered)	White	Ground active wire at switch when clutch is depressed.	Cruise will not function if wrong wire is connected -OR- ⚠️ Cruise will not disengage when clutch is depressed.
Clutch (+12V triggered)	Yellow	+12V active wire at switch when clutch is depressed.	Cruise will not function if wrong wire is connected -OR- ⚠️ Cruise will not disengage when clutch is depressed.

5 Terminal Relay for Brake Switch

