

CONTROL SWITCH & LEVER ASSEMBLY
250-3020, 250-3021, 250-3032

Notice

The 250-3032 is designed to replace the existing turn signal lever in the vehicle.

The 250-3020, 2503021 are designed to be installed on a turn signal lever which has been cut off as shown below To install turn signal levers 2 conditions must be met.

To install this type of switch on a turn signal lever, two conditions must be met:

1. The shaft of the turn signal lever must be .300" diameter or smaller (a 5/16 bolt is .312).
2. You must be free to cut the turn signal lever off without disturbing any of its functions (there must be no electrical wires running through the lever shaft).

If your turn signal lever is .300" dia. or less, and no wires will be damaged by cutting the lever, proceed as follows:

- a. Measure length of lever from its outboard end to steering column shroud. If this length is 5 5/8" or less, mark lever 1" from shroud. If length is over 5 5/8", mark lever 4 5/8" from outboard end. Cut lever on mark. Figure 1

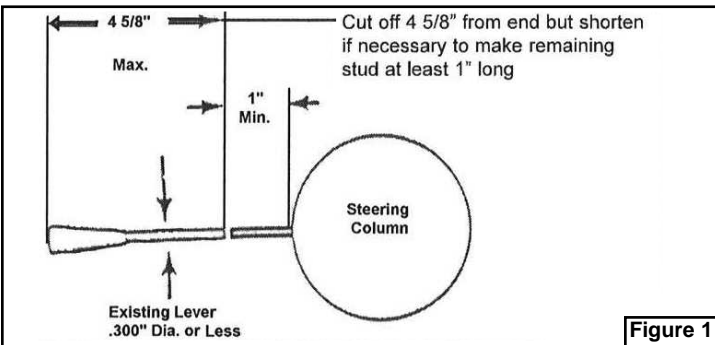

Figure 1

- b. Slide switch and lever assembly onto stud, rotate so lettering is visible to driver, and tighten two set screws. Figure 2

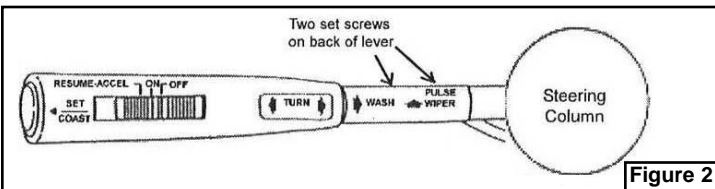

Figure 2

- c. Route switch harness down outside of steering column. On those vehicles which have a supporting clamp or lower trim panel around steering column, remove panel, feed harness through and replace panel. File notch to clear harness if panel is close fitting. See Figure 3. Make certain wires are not pinched or rubbed by moving parts. Switch harness will be connected to main wiring harness later.

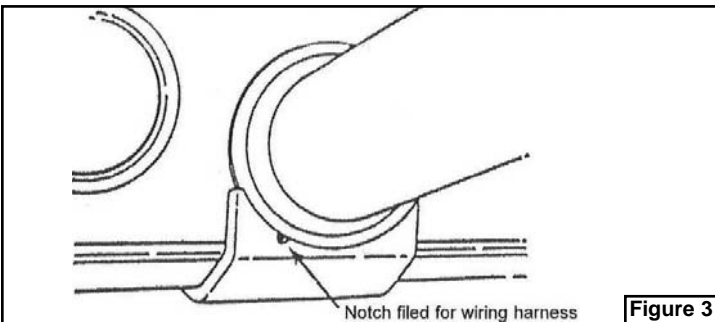

Figure 3



CONTROL SWITCH & LEVER ASSEMBLY
250-3020, 250-3021, 250-3032

Notice

The 250-3032 is designed to replace the existing turn signal lever in the vehicle.

The 250-3020, 2503021 are designed to be installed on a turn signal lever which has been cut off as shown below To install turn signal levers 2 conditions must be met.

To install this type of switch on a turn signal lever, two conditions must be met:

1. The shaft of the turn signal lever must be .300" diameter or smaller (a 5/16 bolt is .312).
2. You must be free to cut the turn signal lever off without disturbing any of its functions (there must be no electrical wires running through the lever shaft).

If your turn signal lever is .300" dia. or less, and no wires will be damaged by cutting the lever, proceed as follows:

- a. Measure length of lever from its outboard end to steering column shroud. If this length is 5 5/8" or less, mark lever 1" from shroud. If length is over 5 5/8", mark lever 4 5/8" from outboard end. Cut lever on mark. Figure 1

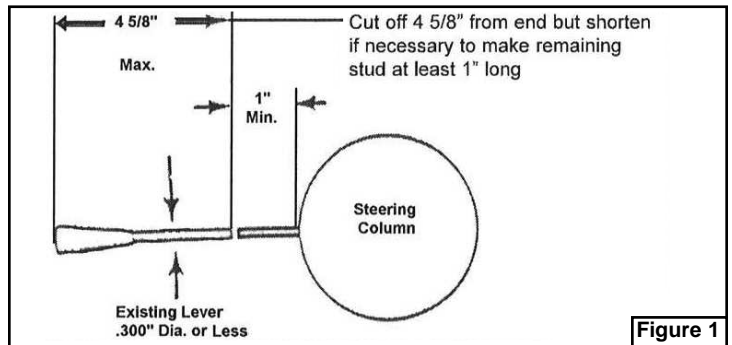

Figure 1

- b. Slide switch and lever assembly onto stud, rotate so lettering is visible to driver, and tighten two set screws. Figure 2

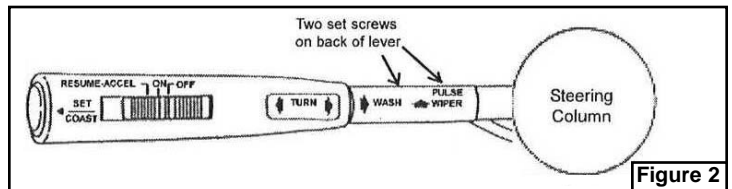

Figure 2

- c. Route switch harness down outside of steering column. On those vehicles which have a supporting clamp or lower trim panel around steering column, remove panel, feed harness through and replace panel. File notch to clear harness if panel is close fitting. See Figure 3. Make certain wires are not pinched or rubbed by moving parts. Switch harness will be connected to main wiring harness later.

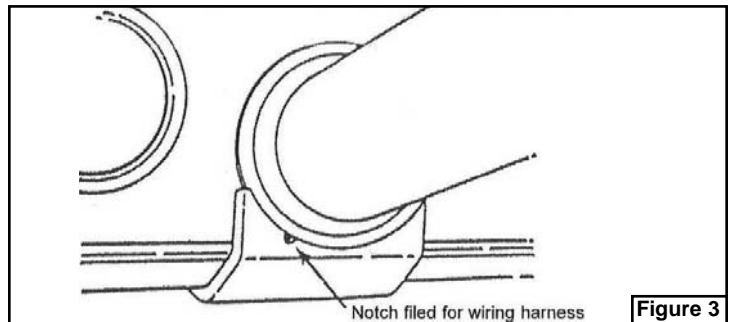

Figure 3

